

The Acoustic Box

Pump & Filter Enclosures



What Is The Acoustic Box?



Australian-made soundproof boxes designed to reduce noise from pool pumps, compressors and other machinery; while protecting equipment from the elements. Supplied and delivered Australia-wide.

Soundproof Compliance saves \$\$\$ Off Energy Bills!



Lined with premium 20mm acoustic grade foam, delivering up to 80% noise reduction. Independently certified by an Acoustic Engineer's report, it allows pumps to run during off-peak hours while helping create a quieter, more enjoyable outdoor space.

Easy To Assemble



Fast, simple assembly in as little as 15-30 minutes. Industrial-grade, lighter and best in market. With just three main parts that click together, most models can be assembled by one person; no building experience required. Every order includes illustrated instructions and a helpful YouTube assembly video.

Superior Design



Made from 0.9mm BlueScope galvanised steel with gas struts and a removable door for clear and easy equipment access. Finished with Dulux Colorbond powder coating. Superior design allows airflow without water leaks or compromising noise reduction. All backed by a 7-year warranty for total peace of mind.



Reduce noise by 80%



Assembles in as little as 15 minutes



Offer more internal space for easier access



Save money on design, equipment and running costs



Child Safety Features



100% Australian Made

Over 300 sizes available and ready to customise.

- ▶ Choose Freestanding, Backless or Deep Backless dependant on your install location.

Freestanding model needs 50mm clearance behind for lid to open. Less than 50mm requires Backless model.

- ▶ Choose your required Height, Width and Depth.
- ▶ Choose your colour from 10 Colorbond options or a custom colour with no additional lead time.

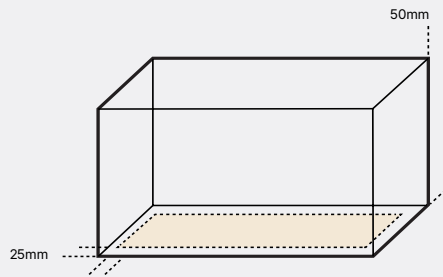

Inside clearance of box less 25mm from outside measurement

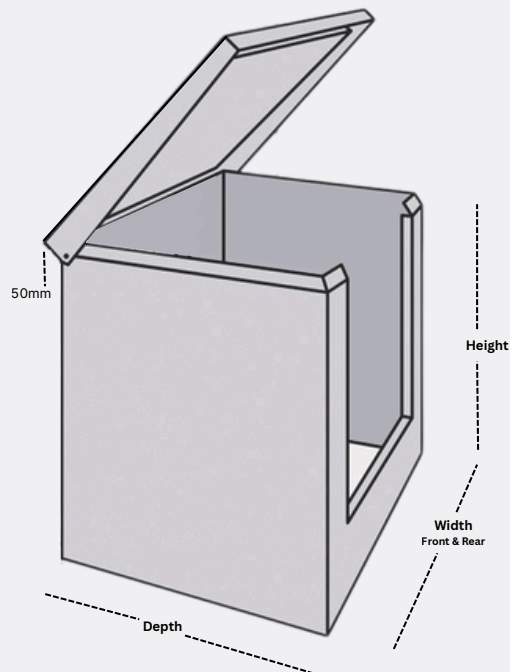

Choose your Height

- ▶ 900mm
- ▶ 1145mm
- ▶ 1345mm
- ▶ 1845mm

Choose your Width

- ▶ 660mm
- ▶ 900mm
- ▶ 1100mm
- ▶ 1350mm
- ▶ 1650mm

Choose your Depth

- ▶ 660mm
- ▶ 900mm
- ▶ 1100mm
- ▶ 1350mm

Add 50mm/150mm for Backless/Deep Backless

Extended widths achieved by modular combinations, allow +28mm per joiner
e.g. 2028mm wide = 1100mm module + 900mm module + 28mm joiner

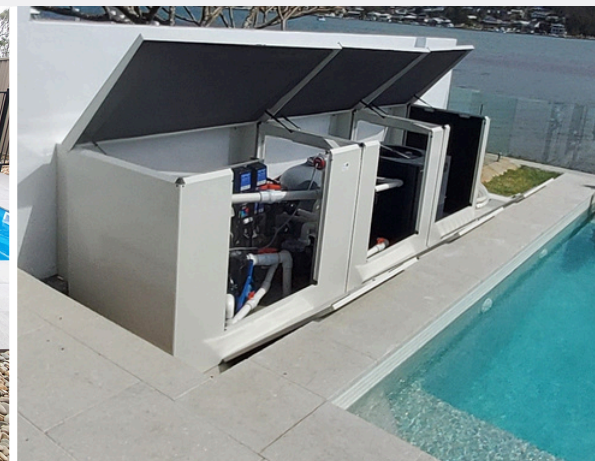

Footings, Custom Boxes & Deliveries

- ▶ Treated timber footings available, cut to size and ready to assemble
- ▶ Ventilated solutions available to accommodate gas and electric pool heaters
- ▶ Custom colours on request – no additional lead time
- ▶ Boxes with side access and extra timber panels
- ▶ Custom tailored solutions to suit any level site
- ▶ Deliveries to all cities and regional towns

Available in 10 Colorbond Colours



1300 787 089

hello@acousticbox.com.au

theacousticbox.com.au